

## New Solid State Sensors with selective membrane for Free Chlorine

CHEMTROL® is introducing new PPM sensors for direct measurement of FREE CHLORINE in water in parts per million (ppm) or milligrams per liter (mg/l). Unlike other chlorine sensors on the market, these sensors are very precise and so reliable that they are covered by a 2-year warranty. They are easy to install and practically maintenance free.

For best water management, it is recommended to use ORP control of chlorine oxidizing activity and PPM monitoring of free chlorine.

Alternatively, PPM control can be used for control of the sanitizer and ORP control for a non-chlorine oxidizer.



## PPM, ORP and pH

For best results in water management, it is recommended to use both ORP control of free chlorine and PPM monitoring of total and combined chlorine. Alternatively, PPM control can be used for control of the sanitizer and ORP control for an oxidizing agent, such as ozone.

The chlorine sensor is now available with the CHEMTROL(R) CH255 and CH265 Digital Controllers for PPM and pH.

It is also available with the CHEMTROL(R) programmable controllers (PC) range for simultaneous ORP control or monitoring of the activity of FREE ACTIVE CHLORINE, HOCl.

### A CHOICE OF RANGES

The following standard ranges are available:

- P/N PPM002 from 0.02 to 2 ppm,
- P/N PPM010 from 0.1 to 10 ppm.

Other sensors are available for measurements up to 200 ppm.



## FEATURES

- ✓ Direct FREE CHLORINE measurement including:
  - free chlorine (HOCl and OCl-) and
  - combined isocyanurates if present
  - corresponding to the DPD1 test.
- ✓ pH RANGE of 5.5 to 9.5,
- ✓ TEMPERATURE RANGE of 5 to 50C (40 to 120 F)
- ✓ CYANURIC ACID compatible,
- ✓ PRESSURE RANGE up to 3 bars (45 psi),
- ✓ PVC BODY with 1" MPT fitting,
- ✓ REPLACEABLE MEMBRANE and electrolyte,
- ✓ FLOW CELL with specially designed probe housing,
- ✓ EASY CALIBRATION on startup.

# SANTA BARBARA CONTROL SYSTEMS

Santa Barbara, California USA

Leader in Chemical Automation since 1976



# INSTALLATION AND OPERATION

## FLOW CELL INSTALLATION

The sensor is designed to be installed in a specially designed flow cell for controlled flow of water. Install the flow cell on a bypass line with 3/8" tubing as shown on the right. Make sure that the bypass line is located after the filter and that there is a sufficient but not excessive flow of water. The recommended flow rate is about 30l/h (0.2 gal/min).

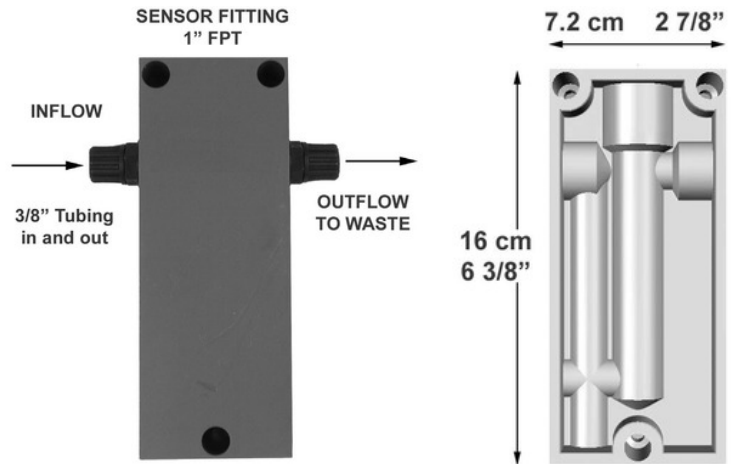

## SENSOR INSTALLATION

The chlorine sensor is shipped in a molded foam package containing:

- One (1) PPM sensor with serial number (needed for warranty),
- One (1) compression fitting with O-ring and compression disk,
- One (1) electrolyte cap with membrane,
- One (1) electrolyte bottle and screw-on filling tip,
- One (1) screwdriver (not needed if pre-wired).

In order to prevent serious damage to the sensor, be careful not to touch the membrane or the electrodes.

To facilitate shipment and storage of the sensor, it is not fitted with the electrolyte cap until ready for installation. The sensor cap must be filled with the electrolyte solution before usage and emptied during storage.



Fill the sensor cap with the electrolyte taking care to prevent air bubbles. Fill the cap to the bottom of the threaded section. Thread the sensor into the cap as far as it will go. Excess air and electrolyte may escape through the hole below the rubber seal. Wipe any excess electrolyte with a soft tissue. Contact your CHEMTROL(R) dealer if you need additional electrolyte.

Slide the O-ring and the compression disk over the sensor tip up to the compression ring. Finally, insert the sensor with the compression fitting in the flow cell and make it finger tight.

## SENSOR CALIBRATION

To calibrate the sensor, use a DPD or OTO test kit for total chlorine. It is recommended to do the first calibration 2 hours after startup and to repeat it after 24 h. After that, check the calibration as required and generally every 3 to 4 weeks.



## SENSOR MAINTENANCE

There is no special maintenance requirements except to make sure that the membrane remains clean and to replace the membrane and electrolyte when needed. In winter, remove the sensor to prevent freezing if applicable. Do not reuse the membrane once removed. Replace with new membrane and electrolyte.