

# INSTRUCTION MANUAL

**CHEMTROL® 255/265 PPM/pH Controller (version 2010)**  
**CHEMTROL® 230/240/250 ORP/pH Controller (v. 4.5 and up)**



With  
New Improved  
Free Chlorine Sensor

<b>TECHNICAL SUPPORT</b>	
<b>AUSTRALIA</b>	<b>1300-585-820</b>
<b>EMAIL</b>	<a href="http://www.chemtrol.com.au">www.chemtrol.com.au</a>



A Division of **SANTA BARBARA CONTROL SYSTEMS**  
California USA

## IMPORTANT SAFETY INSTRUCTIONS

Mandated by ITS Testing Laboratories, Inc

1. **READ AND FOLLOW ALL INSTRUCTIONS**
2. **WARNING** - To reduce the risk of injury, do not permit children to use this product unless they are closely supervised at all times.
3. **WARNING** - Risk of Electric Shock. Connect only to a grounding type receptacle protected by a ground-fault circuit interrupter (GFCI). Contact a qualified electrician if you cannot verify that the receptacle is protected by a GFCI. (Only required for cord-connected units.)
4. Do not bury cord. Locate cord to minimize abuse from lawn mowers, hedge trimmers, and other equipment. (Only required for cord-connected units.)
5. **WARNING** - To reduce the risk of electric shock, replace damaged cord immediately. (Only required for cord-connected units.)
6. **WARNING** - To reduce the risk of electric shock, do not use extension cord to connect unit to electric supply; provide a properly located outlet. (Only required for cord-connected units.)
7. **SAVE THESE INSTRUCTIONS.**

## WARRANTY

This **CHEMTROL**<sup>®</sup> Electronic Controller Model \_\_\_\_\_ S/N \_\_\_\_\_ is warranted by SANTA BARBARA CONTROL SYSTEMS (SBCS) to be free from defects in manufacturing and workmanship for a period of FIVE (5) YEARS from the date of purchase for the electronic module and ONE (1) YEAR for all other components. SBCS will repair or replace, at its option, any defective part during the warranty period. Labor, shipping or incidental expenses are specifically excluded from this warranty. For warranty coverage, defective parts should be returned immediately to your **CHEMTROL**<sup>®</sup> Dealer or to our factory postpaid with a copy of your purchase receipt and a detailed description of the malfunction.

## TABLE OF CONTENTS

TECHNICAL SUPPORT	1	OPERATION	9
WARRANTY	2	PPM SENSOR CONDITIONING	9
INTRODUCTION	3	CALIBRATION OF SENSORS	9
FREE CHLORINE	3	CONTROL SETPOINTS	9
ORP CONTROL (Models 230/250)	3	OVERFEED SAFETY TIMERS	9
PPM CONTROL (Models 255 and 265)	3	OUT-OF-RANGE ALARMS	10
WATER CHEMISTRY	3	FEED MODE	10
INPUTS AND OUTPUTS	3	PROPORTIONAL FEED	10
INSTALLATION (CH230, CH240, CH250)	4	CONTROLLER RESET	10
LOCATION	4	STARTUP	10
SENSOR INSTALLATION (pH and ORP)	4	DEFAULT PARAMETERS	10
MAIN LINE INSTALLATION	4	AUTOMATIC CONTROL	10
BYPASS LINE INSTALLATION	5	MAINTENANCE	11
SENSOR CELL	5	GENERAL MAINTENANCE	11
WATER FLOW	5	EFFECT OF CYANURIC ACID	11
INSTALLATION (CH255 and CH265)	6	PPM SENSOR TESTING	11
PPM SENSORS	6	PPM SENSOR MAINTENANCE	11
PPM SENSOR FLOW CELL	6	NO PPM SENSOR CLEANING	11
PPM SENSOR INSTALLATION	7	ORP AND pH SENSOR TESTING	11
ELECTRICAL	7	ORP AND pH SENSOR CLEANING	11
UNINTERRUPTED POWER SUPPLY	7	SENSOR REPLACEMENT	11
OPERATING VOLTAGE	7	SENSOR STORAGE	11
POWER TERMINAL BLOCK WIRING	7	WINTERIZING	11
REMOTE ALARM	8	PORTABLE TESTER	12
FLOW SWITCH	8	ORP SENSOR TESTING	12
SETUP MENU	8	pH SENSOR TESTING	12
ACID/BASE FEED	8	ORP AND pH SIMULATION	12
SANITIZER/pH INTERLOCK	8	TROUBLESHOOTING	13
SAFETY FLOW SWITCH	8	LIST OF FIGURES	13
CHEMICAL FEEDERS	9	PARTS LIST	14
CHEMICAL FEED PUMPS	9	OPTIONS	14
EROSION FEEDER	9	SPECIFICATIONS	14

## INTRODUCTION

The **CHEMTROL<sup>®</sup> 250 Series Controllers** are microprocessor-based digital controllers designed to monitor and control the sanitizer and pH levels in swimming pools, spas, cooling towers and industrial applications.

The controllers are available with three types of sensors for measurement of water acidity (pH) and of sanitizer level in either PPM (parts per million or milligrams/liter) or ORP in millivolts.

This manual covers new versions (2010) of five models:

- **CHEMTROL<sup>®</sup> 265** PPM/pH Controller (4-20 mA outputs),
- **CHEMTROL<sup>®</sup> 255** PPM/pH Controller (ON/OFF outputs),
- **CHEMTROL<sup>®</sup> 250** ORP/pH Controller,
- **CHEMTROL<sup>®</sup> 240** pH Controller,
- **CHEMTROL<sup>®</sup> 230** ORP Controller.

### FREE CHLORINE

As shown on the dissociation curve on the right, Free Chlorine in water is in equilibrium under two forms:

- Molecular HOCl, a strong sanitizer and oxidizer,
- Ionized OCl<sup>-</sup>, a weak sanitizer and oxidizer.

At a pH of 7.5, the two forms are in equal proportions of 50% each. At lower pH values, HOCl predominates. At higher pH values, OCl<sup>-</sup> is dominant.

### ORP CONTROL (Models 230/250)

The ORP sensor shows the voltage (in mV) produced by oxidizers in water.

It responds to strong oxidizers, such as HOCl and its bromine equivalent HOBr. It also responds to other strong oxidizers that are used in water treatment, such as Ozone (O<sub>3</sub>) or Potassium Monopersulfate (KSO<sub>3</sub>).

Because HOCl is the primary oxidizer, the signal of the ORP sensor decreases with increasing pH values.

It is not specific to chlorine or bromine and responds to other oxidizers.

The chlorine or bromine concentration required to generate a desired ORP value varies with pH and overall water quality, particularly Total Dissolved Solids (TDS) concentration, organic load and cyanuric stabilizer concentration.

The ORP setpoint default value on the controller is 700 mV, which is recommended to kill germs and bacteria and maintain good water quality.

### PPM CONTROL (Models 255 and 265)

Direct **FREE CHLORINE** measurement including:

- free chlorine (HOCl and OCl<sup>-</sup>) and
- chlorinated isocyanurates if present, corresponding to the DPD1 test.

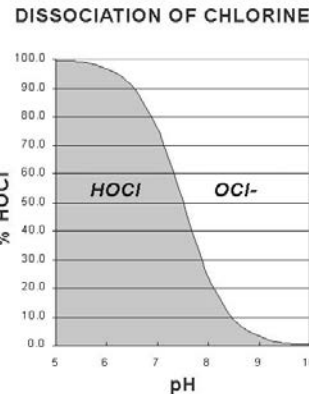

Figure 1 - Equilibrium of Free Chlorine

The controller displays the concentration of Total Free Chlorine (HOCl + OCl<sup>-</sup>) in PPM (parts per million or milligrams/liter). It does not respond to Bromine and/or oxidizers.

The Free Chlorine display does not vary up to a pH of 7.8.

The PPM setpoint default value on the controller is 1.0 ppm, which is recommended to kill germs and bacteria and maintain good water quality. It can be adjusted to meet local conditions and Health Department requirements.

### WATER CHEMISTRY

Before starting automatic control, test the water chemistry to make sure that the pH, Cyanuric Acid and Total Dissolved Solids are within the ranges recommended by the National Spa and Pool Institute (NSPI).

The **pH should be adjusted manually within 7.4 to 7.6**. If it is below 7.0 or above 8.0, the controller will show an alarm condition and prevent feeding (programmable option).

To stabilize chlorine against solar UV radiation, a **cyanuric acid level of 20 to 25 ppm** is ideal. However, this level can be quickly exceeded with stabilized chlorine (dichlor or trichlor). Note that many Health Department codes do not allow stabilizer levels above 100 ppm. If above 100 ppm, this results in *chlorine lock* that shows as low ORP readings even with high chlorine levels.

The **Total Dissolved Solid (TDS) level should be below 2,000 ppm**. If higher, the water is full of organic and inorganic impurities and should be dumped and replaced partially or completely.

For effective pH control, the **Total Alkalinity should be between 80 to 120 ppm**. If too low, the pH will bounce and be hard to control. If too high, the pH will be hard to change.

### INPUTS AND OUTPUTS

Depending on the model number, the inputs include one or two sensors:

- a PPM sensor to monitor free chlorine concentration,
- an ORP sensor to monitor ORP or Redox,
- a pH sensor and a safety flow switch (optional).

The outputs are two relays for sanitizer and pH feed - acid or base - plus a relay for an optional remote alarm or telephone dialer.

## INSTALLATION (CH230, CH240, CH250)

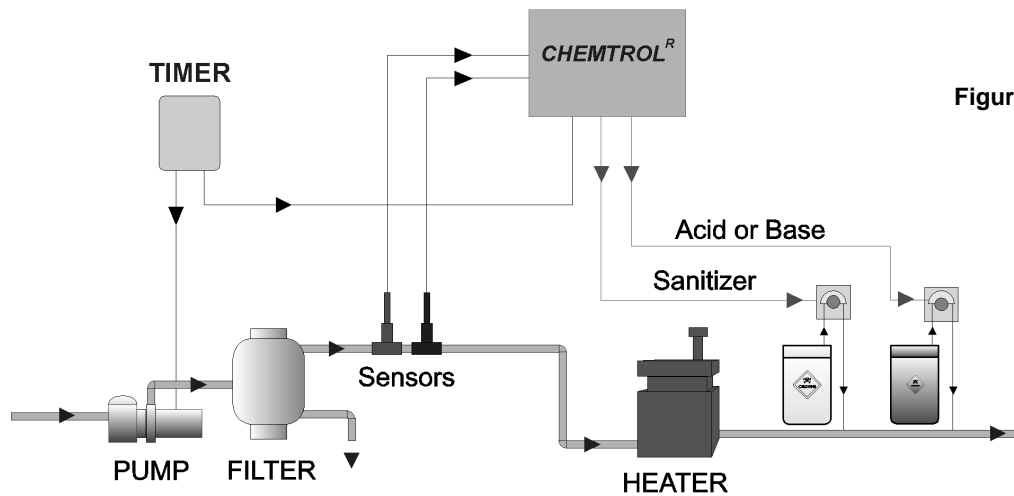

Figure 2 – CH250 Installation on Main Line

### LOCATION

Mount the controller cabinet on a wall in a secure location, as shown on the schematic:

- more than 10' (3 m) away from the water edge to comply with electrical code requirements,
- if possible, not more than 10' (3 m) of the main recirculation line or of the bypass line. The sensors come with standard 10-foot (3-m) cables. If needed, you can order 25 or 50-ft BNC extension cables from your dealer.
- not exposed to direct sunlight,
- easily accessible to maintenance personnel,
- if possible in a separate room, or in a well-ventilated room as far away as possible from corrosive chemicals and storage tanks,
- at a safe distance from power transformers, pump motors or high voltage power lines
- safe from unauthorized access or vandalism.

### SENSOR INSTALLATION (pH and ORP)

**Save the sensor caps** for storage or shipping of the sensors. When in storage or shipping, add salt water in the cap to keep the sensors from drying out. During winter, store the sensors above freezing temperature.

The sensors can be mounted three different ways:

- directly on the main recirculation line) (2 in. pipe only),
- on a 1/2 in. bypass line as shown,
- even better, in a sensor cell mounted on the bypass line (Figure 5).

### MAIN LINE INSTALLATION

On smaller installations (2" pipe diameter), the sensors can be mounted directly on the main recirculation line).

Use only the 2x2x1/2 in. SST reducing tees without reducers (Do not install the sensors near an elbow or a constriction where there might be excessive turbulence).

Install the tees after the pump and filter. Insert the sensor tip down so that the tip is about 1/4 inch (1 cm) in the water. The sensors should be readily accessible for servicing but not exposed to physical damage.

Tighten the compression fitting by hand only to avoid breaking the internal glass tube in the sensors. Do not use a wrench!

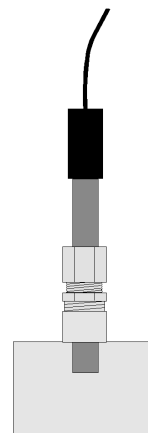

Figure 3 – ORP or pH Sensor in PVC Tee

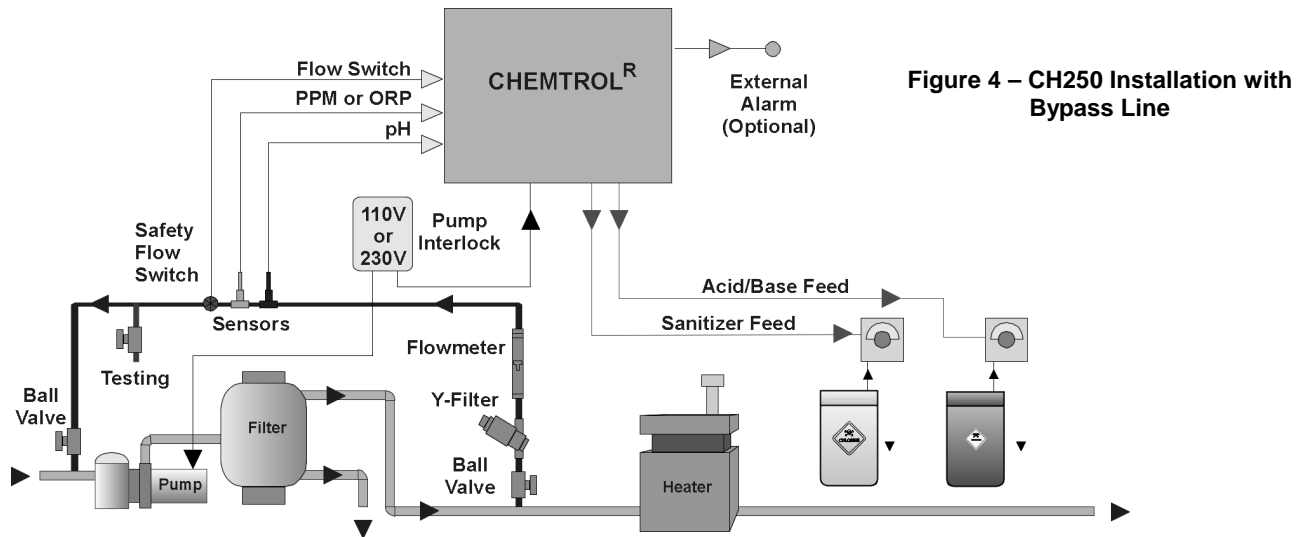

Figure 4 – CH250 Installation with Bypass Line

**BYPASS LINE INSTALLATION**

To facilitate installation of the sensors and to assure a smooth and steady flow of water by the sensors, it is recommended to install the optional Bypass Line Assembly (P/N BPL-0.5). As shown in Figure 4, it includes:

- two (2) compression gland fittings (1/2" MPT),
- two (2) PVC tees (1/2" SST),
- one (1) in-line Y-filter (3/4" MPT),
- one (1) in-line flowmeter (1/2" FPT),
- one (1) rotary safety flow switch (1/2" FPT),
- two (2) ball valves (1/2" SxS) for flow adjustment and for isolating the bypass line during backwashing of the filter and other maintenance operations,
- one (1) spigot (1/2" SxS) for water sampling and testing.

The Bypass Line Assembly should be installed exactly as shown on Figure 4. In particular, make sure to install the flowmeter in a vertical position and to install the flow switch downstream (after the sensors) to assure a smooth flow of water near the sensors.

**SENSOR CELL**

For additional ease of installation and maintenance, it is also recommended to mount the sensors in the optional Flow Cell Assembly as shown in Figure 5. It includes:

- the sensor cell with air vent and clear cover,
- two (2) compression fittings for the sensors,
- one (1) water sampling tap
- two (2) ball valves for controlling the water flow in and out.

**WATER FLOW**

Proper flow of water past the sensors is essential to obtaining good readings.

To ensure proper water flow, make sure that the bypass line is properly connected. As shown in Figure 4, the intake side should be on the effluent side of the recirculation system, i.e. after the filter. The return side should be to a low-pressure area - such as the vacuum side before the recirculation pump, or downstream after the heater, or atmospheric pressure in the pit of a vacuum sand filter or balancing tank.

To check the water flow in the bypass line, start the main recirculation pump. Open both the intake and the return valves on the bypass line and read the flow rate on the flowmeter. It should be in the middle of the range, i.e. about 2-3 gpm (about 8 to 12 l/min). If the water flow is too high, you can turn down the valve on the RETURN SIDE of the bypass line. If there is no water flow, replumb the bypass line as shown on the schematic.

**NOTE: Most common installation problems with bypass line installations are caused by faulty hydraulics.**

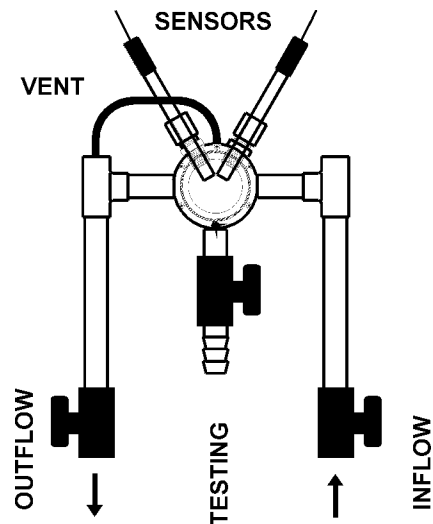

Figure 5 – Flow Cell Assembly

## INSTALLATION (CH255 and CH265)

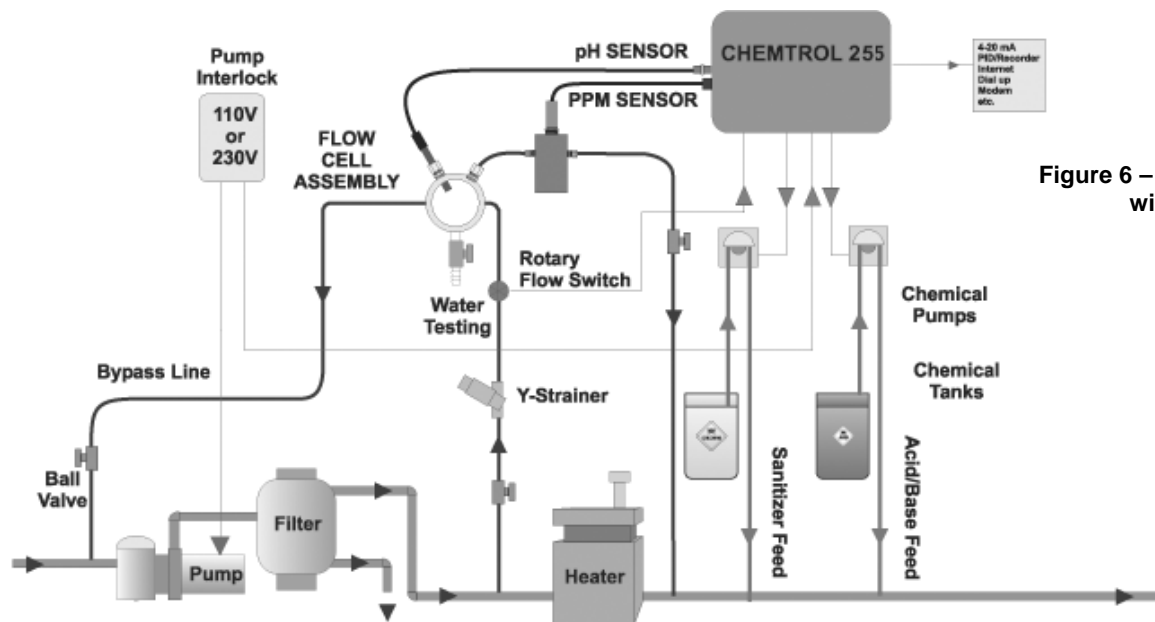

Figure 6 – CH255/265 Installation with 2 Flow Cells

### PPM SENSORS

The following new, improved PPM Sensors (Model 2010) are available with the CH255 and CH265 controllers:

- PPM002 for 0-2 PPM (mg/l) of Free Chlorine
- PPM010 for 0-10 PPM (mg/l) of Free Chlorine

Both use the same membrane Part Number PPM01

- PPM200 for 0-200 PPM (mg/l) of Free Chlorine with membrane part number PPM02
- PPM010 Membraneless Sensor for electrolytic chlorine generators.

### NOTES

1. These new sensors are not affected by cyanuric acid - therefore the new CH255/265 (Version 2010) have no GAIN FACTOR adjustment.

2. All sensors use the same flow cell PPMCLL and do not require the plastic spacer ring.

### PPM SENSOR FLOW CELL

The PPM Sensor must be installed in the specially designed flow cell for better water flow control. Install the flow cell on a bypass line with 3/8" tubing as shown above.

Make sure that the bypass line is located after the filter and that there is a sufficient but not excessive flow of water. The recommended flow rate is between 20 to 100 l/h (0.1 to 0.6 gal/min.) with a best value of about 30l/h (0.2 gal/min.).

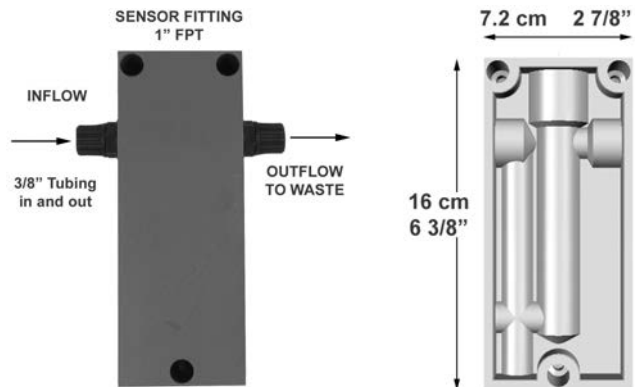

Figure 7 - PPM Sensor Cell

### SPAS

For a spa, it is recommended to increase the flow rate sufficiently to avoid the formation of air bubbles and to install the cell horizontally with the inflow coming in from the bottom.

**PPM SENSOR INSTALLATION**

The new PPM Sensors are shipped in a molded foam package containing:

- One (1) chlorine sensor with warranty serial number,
- One (1) compression fitting with O-ring,
- One (1) electrolyte cap with membrane,
- One (1) electrolyte bottle and screw-on filling tip,
- One (1) screwdriver (not needed if pre-wired).

In order to prevent serious damage to the sensor, be careful not to touch the membrane or the electrodes. To facilitate shipment and storage of the sensor, it is not fitted with the electrolyte cap until ready for installation. The sensor cap must be filled with the electrolyte solution immediately before usage and emptied during storage.

Fill the sensor cap with the electrolyte taking care to prevent air bubbles. Fill the cap to the bottom of the threaded section. Thread the sensor into the cap as far as it will go while making sure not to touch the membrane film at the bottom with your fingers. Excess air and electrolyte may escape through the hole below the rubber seal. Wipe any excess electrolyte with a soft tissue. Contact your CHEMTROL<sup>®</sup> dealer if you need additional electrolyte.

Slide the O-ring over the sensor tip up to the compression ring. Finally, insert the sensor with O-ring in the flow cell and make it finger tight.

*For best performance, it is recommended to change the membrane cap and electrolyte at least once a year.*

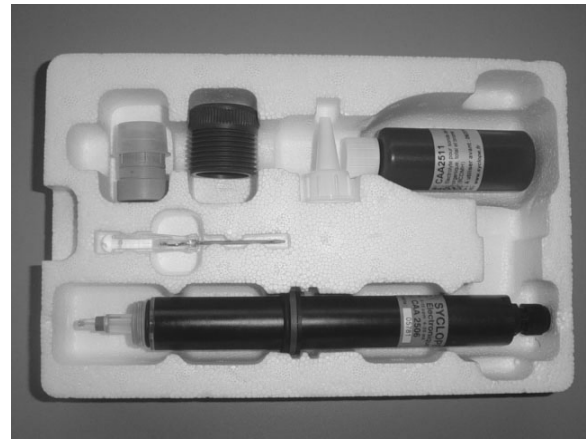

**Figure 8 - PPM Sensor Package**

**PPMSLT SENSOR**

The PPMSLT sensor does not use a membrane and has a different open-through cap that holds the electrolyte solution around the electrodes glass shaft. Because this cap is opened from both sides, the procedure to fill it with the necessary electrolyte is slightly different in that you must do so with the accompanied lid on before fully screwing that cap onto the electrodes then finally removing that lid.

The PPMSLT sensor is the only sensor that requires cleaning of its gold electrodes tip and you do so with the small special abrasive cleaner the sensor is shipped with.

**ELECTRICAL**

***Make sure to follow all local electrical codes.***

Always **interlock the controller with the timer on the main power supply** (see **Error! Reference source not found.**) to prevent injection of chemicals when the recirculation pump is not running.

**UNINTERRUPTED POWER SUPPLY**

It is highly recommended to use a power conditioning protection system, such as a UPS (Uninterrupted Power Supply) to protect the integrated circuits (ICs) in the controller that are susceptible to power spikes, lightning, etc.

To prevent electrical shock, make sure that the power is disconnected before opening the cabinet.

The Mother Board is mounted behind the front panel and the Power Board (Figure 9) in the back of the controller.

**OPERATING VOLTAGE**

The operating voltage is factory set for **110, 230 or 24 VAC**.

Make sure to **check the voltage before installation** to avoid damage to the control board and **void the warranty**. 110 V units have a power cord with a 3-prong plug. 230 V units have bare wires. 24 V units do not have a transformer. You can also check Jumpers JP5 on the Power Board (Figure 9).

All outputs voltages are the same as the input voltages.

**POWER TERMINAL BLOCK WIRING**

HOT CMN GND	+ 5V SIG GND Red White Black	SIG GND	HOT CMN GND	HOT CMN GND	HOT CMN GND
<b>SANITIZER FEED AC OUT</b>	<b>PADDLE WHEEL DC IN</b>	<b>FLOW SWITCH</b>	<b>POWER AC IN</b>	<b>ALARM AC OUT</b>	<b>ACID/BASE FEED AC OUT</b>

LINE 1.....BLACK (HOT)  
 LINE 2.....WHITE (NEUTRAL)  
 GROUND.....GREEN (GROUND)

**BLUE TERMINAL BLOCK**

**PADDLE WHEEL FLOW SWITCH**

TB2-1 (+5v) Red Wire  
 TB2-2 Signal White Wire  
 TB2-3 Ground Black Wire

**FLOW SWITCH**

TB2-4 Signal Dry Contact  
 TB2-5 Ground Flow Switch

**ALARM JUMPERS**

The alarm is hot by default.  
 JP6 jumpers for the alarm relay output are set on pins 1-2 and 3-4 by factory.  
 Jump pins 2-3 instead for dry contact alarm function.

**FUSE CONFIGURATION**

F1 + F2	5A Slow blow	Sanitizer feed
F3 + F4	5A Slow blow	Acid/Base feed
F5 + F6	5A Slow blow	Alarm
F7	2.50A Slow Blow	For 24VAC Controllers
F7	1.0A Slow Blow	For 120/240VAC Controllers

**REMOTE ALARM**

The remote alarm is connected through the terminal block as shown below. It can be used to activate a remote alarm such as a light, a buzzer, or a bell, or even an automatic telephone dialer with voice messaging capability.

The Alarm Jumpers JP6 (Figure 9) are normally set for a HOT (powered) contact with two jumpers in the 1-2 and 3-4 positions. For a dry (N.O.) contact, set one jumper only in position 2-3.

**FLOW SWITCH**

Note: with a bypass line, a **Safety Flow Switch is absolutely required** to prevent accidental feeding of chemicals if the line is shut off or obstructed.

The rotary paddlewheel flow switch connects to the controller terminal block as shown below using the + 5V power input. **DO NOT CONNECT TO HIGH VOLTAGE.**

A blade flow switch uses a dry contact that connects as shown below to interrupt the power output. Make sure to orient the flow switch in **the direction of flow.**

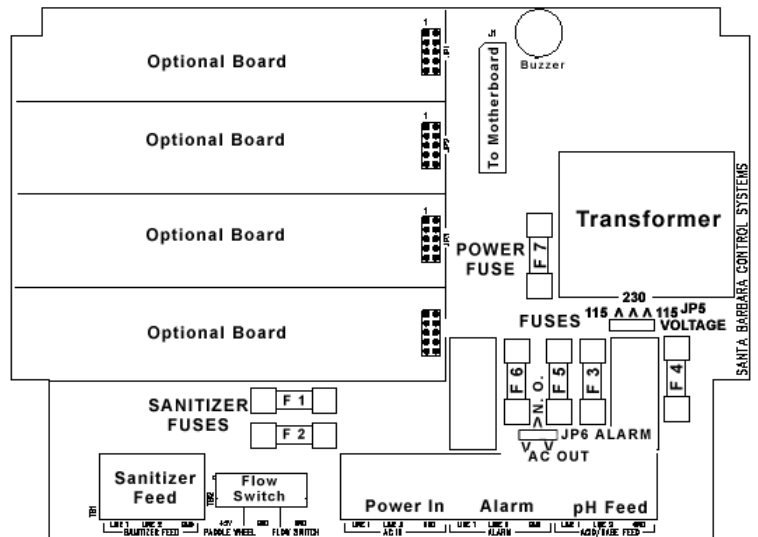

Figure 9 – Power Board

**SETUP MENU**

Upon startup, the Setup Menu is displayed. You can also recall it at any time by pressing both arrow keys simultaneously.

**ACID/BASE FEED**

The Setup Menu first displays PHF (pH Feed) and either AC for Acid Feed (default value) or bA for Base Feed. Press either arrow to change the setting.

Acid Feed is used for all basic (alkaline) sanitizers: liquid chlorine (sodium hypochlorite NaOCl) or dry chlorine (calcium hypochlorite Ca(OCl)<sub>2</sub>). Base Feed is used only for acidic sanitizers (trichlor tablets).

**SANITIZER/pH INTERLOCK**

The Setup Menu then displays IL for Interlock and either 0 for OFF or 1 for ON (default value).

The Sanitizer/pH Interlock is a safety feature designed to deactivate the sanitizer feed when the pH is out of range. This is particularly important with liquid chlorine, a strong basic chemical that raises the pH of the water.

**SAFETY FLOW SWITCH**

The Setup Menu then displays FLO for Flow Switch with either 0 for OFF or 1 for ON (default value).



## CHEMICAL FEEDERS

Make sure to **inject all the chemicals downstream** of the sensors to avoid false readings, and downstream of all equipment (pump, filter, heater) to avoid corrosion.

### CHEMICAL FEED PUMPS

Install the feed pumps for liquid chlorine, calcium hypochlorite or dichlor solutions as shown in **Error! Reference source not found.**, according to the manufacturer's instructions.

### EROSION FEEDER

With an erosion feeder for bromine or chlorine tablets, install a solenoid valve on the intake side of the bypass line to the erosion feeder as shown in Figure 10.

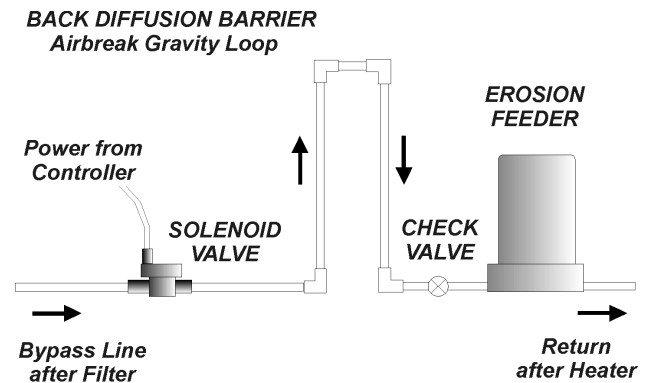

Figure 10 - Erosion Feeder Installation

## OPERATION

### PPM SENSOR CONDITIONING

**IMPORTANT: DO NOT CONNECT THE PPM SENSOR** before the conditioning procedure is completed. **Warranty may be void if sensor is powered without proper conditioning.**

Before using the PPM sensor for the first time – or after long storage in air – it is important to hydrate the sensor. Remove the sensor cap and place the sensor for at least 30 to 60 minutes in water containing a small amount of chlorine without connecting it to the controller.

Please note that the sensor's time response for accurate chlorine reading could take up to 30 minutes after first hydration and up to 15 minutes to stabilize after each water chemistry change.

### CALIBRATION OF SENSORS

No calibration is required for the ORP sensor.

To calibrate the PPM and pH sensors, test the water with a reliable, fresh test kit (DPD and Phenol Red). Note the values and compare to the display values. Re-calibrate if needed, as follows:

- press **[CALIBRATION]**,
- press **[PPM]** or **[pH]**: the display flashes,
- use the **[UP]** and **[DOWN]** arrows to adjust the value,
- press **[CALIBRATION]** again to save the new value.

To calibrate the PPM sensor, use a DPD #1 test kit for free chlorine. It is recommended to do the first calibration 2 hours after startup and to repeat it after 24 h.

### CONTROL SETPOINTS

The PPM setpoint is factory set at 1.0 ppm.

The ORP setpoint is factory set at 700 mV, which is recommended to maintain water quality by killing germs and bacteria. There is no need for ORP calibration.

The pH setpoint is factory set at 7.5, which is recommended for pool and spa applications.

To change a control setpoint:

- press **[SETPOINT]**,
- press **[PPM]**, **[ORP]** or **[pH]** : the display flashes,
- use the **[UP]** and **[DOWN]** arrows to adjust the setpoint,
- press **[SETPOINT]** again to save the new value.

### OVERFEED SAFETY TIMERS

The internal safety timers are designed to alert the operator in case of overfeeding of chemicals as a result of mechanical or electronic failure or empty containers.

The timers are factory set at 15 minutes for PPM or ORP and 5 minutes for pH. This is normally sufficient to reach the setpoint. At that time feeding stops and the timer resets to zero. If the limit is reached however, the feeder is deactivated, the alarm turned on and the display flashes the overfeed time. The operator should then check the chemical feeders, feed lines and tanks. After correcting the problem, the safety timer is reset by switching the feed mode to OFF and then back to AUTO.

To change the limits of a safety timer:

- press **[SAFETY TIMER]**,
- press **[ORP]**, **[PPM]** or **[pH]** : the display flashes,
- use the **[UP]** and **[DOWN]** arrows to adjust the value,
- press **[SAFETY TIMER]** again to save the new value.

**CAUTION:** Increasing the limit on a safety timer may cause overfeeding of chemicals.

## OUT-OF-RANGE ALARMS

The out-of-range alarms are factory set at 650 to 900 mV for ORP, 0.3 to 6.0 for PPM and 7.0 to 8.0 for pH. If the ORP or PPM readings are below the low limit, the red LED alarm flashes *but sanitizer feed continues*.

If the pH limits are exceeded, the red LED alarm flashes and *all feeders (pH and sanitizer) are deactivated* - unless the sanitizer/pH interlock is defeated (see below).

To change an alarm limit:

- press **[LOW LIMIT]** or **[HIGH LIMIT]**,
- press **[PPM]**, **[ORP]** or **[pH]**: the display flashes,
- use the **[UP]** and **[DOWN]** arrows to adjust the value,
- press **[LOW LIMIT]** or **[HIGH LIMIT]** again.

**CAUTION:** Increasing the out-of-range limits may cause overfeeding of chemicals.

## FEED MODE

The feed mode for the sanitizer or pH can be set to OFF, Manual or Automatic. To select the desired feed mode, press **[PPM]**, **[ORP]** or **[pH]** until the corresponding LED indicator light is illuminated. There is a short delay before activation. (Note: Holding the switch for more than 5 seconds resets the setpoint and calibration for **[PPM]**, **[ORP]** or **[pH]** to original factory values).

## PROPORTIONAL FEED

There are two ways to control the feed rate.

In standard ON/OFF control (Figure 11), the feed rate remains constant until the setpoint is reached, whereupon it stops.

In the Proportional Zone, activation of the chemical feeder is based on 1-minute cycles with varying ratios of ON and OFF feed times. As the sensor reading approaches the setpoint value, the ON portion of the cycle decreases progressively. During the OFF portion, the feed light flashes continuously to indicate that the controller is under proportional control.

In proportional control (Figure 12), the feed rate decreases progressively as it approaches the setpoint. Proportional control is particularly useful to avoid overfeeding of chemicals in small bodies of water.

## CONTROLLER RESET

The **CHEMTROL**<sup>®</sup> controller saves all user-defined values as well as factory defaults in its internal non-volatile memory. Therefore, user-modified setpoints and acid/base feed modes will not be lost in the event of power failure and the factory default values can be restored at any time.

To reset the setpoint and calibration values to the original factory values, press and hold **[PPM]**, **[ORP]** or **[pH]** for 5 seconds.

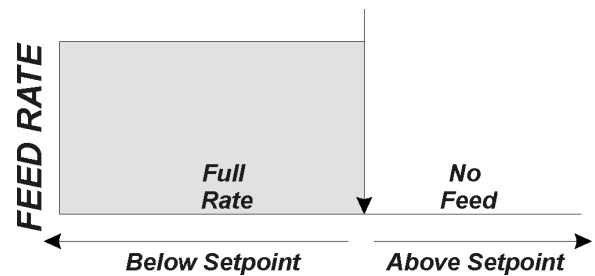

Figure 11 - ON/OFF Control

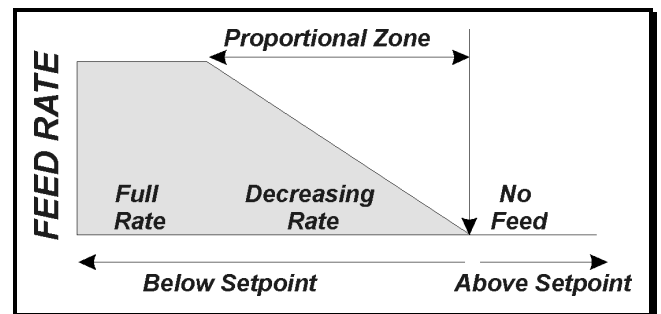

Figure 12 - Proportional Control

## STARTUP

### DEFAULT PARAMETERS

	PPM	ORP	pH
Setpoint	1.0 ppm	700 mV	7.5
High/Low Alarms	0.3/6 ppm	650/900 mV	7.0/8.0
Overfeed Safety Alarm	15 min.	15 min.	5 min.
Proportional Bandwidth	1%	1%	1%

### AUTOMATIC CONTROL

1. Run the recirculation pump with both sensors in line at least 30 minutes to stabilize the sensor readings.
2. Turn the controller on. The displays will show:
  - a. the software version number,
  - b. **[pHF]** with **[AC]** for Acid feed or **[bA]** for Base feed,
  - c. **[IL]** with 0 or 1 if the sanitizer/pH interlock is ON,
  - d. **[FLO]** with 0 or 1 if the flow switch is ON.
  - e. the sensor readings.
3. Press **[ORP]** or **[PPM]** until the feed control light is on AUTO.
4. Press **[pH]** until the feed control light is on AUTO.
5. After 30 minutes, test the pH of the water with a Phenol Red test kit. Adjust the pH calibration if needed.
6. Test the free chlorine or bromine ppm in the water with a DPD test kit. Adjust the PPM or ORP setpoint if required.
7. Test the water regularly as required by local health authorities.

## MAINTENANCE

The **CHEMTROL**<sup>®</sup> controller is virtually maintenance free. The enclosure and front panel can be cleaned with a soft cloth moistened with a mild soap and water solution or a glass cleaner. Do not use abrasives or harsh chemicals.

### GENERAL MAINTENANCE

For commercial and public pools, it is important to test and record the water chemistry readings in compliance with Health Department requirements using a good quality manual test kit. Adjust the pH, ORP or PPM calibration and setpoint as required.

It is important to note that changes in pH, cyanuric acid concentration, TDS (total dissolved solids), and use of additional or alternative sanitizers will all impact the primary sanitizer residual level in comparison to ORP. To maintain a consistent sanitizer residual in parts-per-million (ppm), adjust the ORP setpoint as required.

### EFFECT OF CYANURIC ACID

Increasing cyanuric acid levels reduce the concentration of free chlorine HOCl in water. This affects the effectivity of the sanitizer, as shown by reduced readings for ORP (Model 250) or PPM (Model 255).

The controller reacts by adding more chlorine to compensate for the reduced effectivity. The only remedy is to replace all or part of the water until the cyanuric acid level is reduced.

### PPM SENSOR TESTING

To test the PPM sensor, use a DC Voltmeter and connect it to the HOCl and Ground terminals on the Mother Board, with the PPM sensor in chlorinated water. You should read 2.6 V or higher.

### PPM SENSOR MAINTENANCE

There is no special maintenance requirements except to make sure that the membrane remains clean and to remove the sensor to prevent freezing in winter.

The sensor is covered with a standard manufacturer's warranty of 2 years. Under proper water conditions, the membrane should last 1 to 2 years. Do not reuse the membrane if removed. Replace with a new membrane.

### NO PPM SENSOR CLEANING

Do not clean the PPM sensor. Cleaners will damage the membrane and void the warranty.

### ORP AND pH SENSOR TESTING

To test the sensors on line, carefully add a small amount of white vinegar or dilute acid solution in the skimmer. After a few minutes:

- the pH reading should go DOWN.
- the ORP reading should go UP.

If you still get no response or a sluggish response, clean or replace the sensors as soon as possible.

For additional testing, use the PORTA-PROBE II (Figure 13) Portable Tester, as shown on the next page.

### ORP AND pH SENSOR CLEANING

The sensor tips must be kept clean and free from chemical deposits and contamination to function properly. After saturation in pool or spa water, the sensors may need to be cleaned on a weekly or monthly basis depending on the water quality and other facility-specific characteristics. Slow response and inconsistent readings are indications that the sensors are in need of cleaning.

To clean a sensor, carefully remove it from the compression fitting. Clean the tip of the sensor with a mild liquid detergent (Joy, etc.) solution. Rinse with fresh water and soak the sensor in a mild acid solution for five minutes. Rinse with fresh water and reinstall the sensor.

### SENSOR REPLACEMENT

For optimum controller performance, always use genuine **CHEMTROL**<sup>®</sup> replacement sensors. For preventive maintenance it is also recommended to replace the sensors on an annual basis or as performance diminishes.

### SENSOR STORAGE

Extended exposure to atmospheric conditions will cause the ORP and pH sensor tips to dry out.

The PPM sensor should be stored dry and electrically disconnected.

Always remove and properly store the sensors if the pool or spa is to be winterized or inactive. Store the sensors with the original cap provided, making sure that each cap is filled with the original storage solution or salt water. If the storage containers have been misplaced, store the sensors individually in small glass or plastic containers with clean water covering the sensor tips.

### WINTERIZING

The sensors should be prepared for storage as outlined above and protected from freezing. Although the controller is designed to withstand a broad temperature range, winter storage in a secure location at normal room temperature is recommended.

## PORTABLE TESTER

The PORTA-PROBE II (Figure 13) is a battery-operated portable tester/signal generator designed to test the ORP and pH sensors and to generate calibrated signals to test the controller. It is supplied with a 9V battery and a pair of shielded cables with BNC connectors.

The PORTA-PROBE II is not used to calibrate the sensors. This should be done with a chemical test kit, such as DPD for Free Chlorine and Phenol Red for pH.

It can also be used to test the TDS and Temperature sensors on the **CHEMTROL**<sup>®</sup> PC or CT controllers.

### ORP SENSOR TESTING

Set the Mode Switch to TESTING. Connect the ORP sensor to the ORP BNC connector on the tester. Turn the Selector Knob to ORP.

Place the sensor in balanced water (pH = 7.5 / PPM = 1.0 Cl). You should get an ORP reading within 650 to 750 mV.

Place the sensor in an acid solution. You should get a HIGH POSITIVE reading.

Place the sensor in a BLEACH (liquid chlorine) solution. You should get a LOW POSITIVE reading.

### pH SENSOR TESTING

The PORTA-PROBE II shows actual pH sensor readings in millivolts, as shown on the Table on the right.

Set the Mode Switch to TESTING. Connect the pH sensor to the pH BNC connector on the tester. Turn the Selector Knob to pH.

Place the pH sensor in nearly neutral water (pH = 7.5). You should get a pH reading of about -30 mV.

Place the sensor in an acid solution. You should get a HIGH POSITIVE reading.

Place the sensor in a BLEACH solution. You should get a HIGH NEGATIVE reading.

The linear scale on the right shows the conversion of millivolt readings into pH units.

### ORP AND pH SIMULATION

Set the Mode Switch to SIMULATOR.

Use the two coaxial cables to connect the BNC connectors on the tester to the respective BNC connectors on the controller.

Set the Selector Knob to either pH or ORP Simulator. The readings on the controller should match the readings of the tester display (unless offset by calibration of the pH probe).

The outputs of the ORP and pH simulators can be adjusted with the two small knobs located below the digital display. The ORP range is 0 to 1,000 mV. The pH range is -180 to + 180 mV (10 to 4 on the pH scale). These outputs can be used to test for proper operation of the feed and alarm features of the controller.

NOTE 1: Due to signal stabilization, the readings on the controller may take up to 10 seconds to reach full value.

NOTE 2: ORP and pH signals can be generated simultaneously but only one signal is displayed.

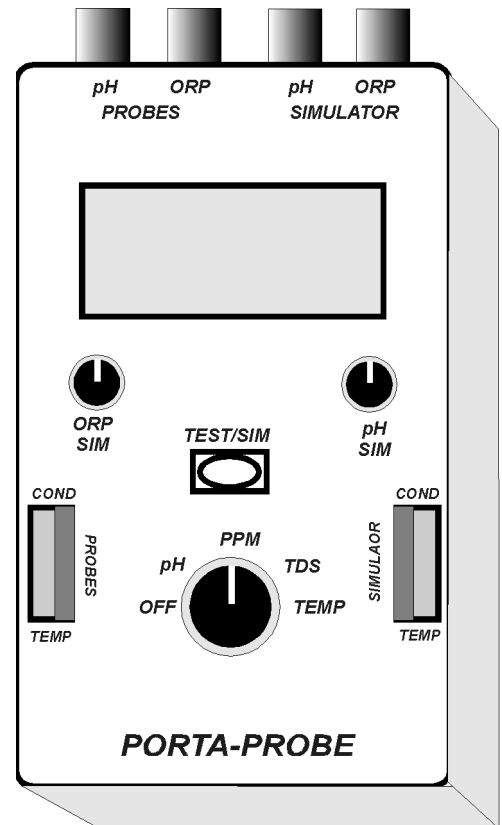

pH Scale	
mV	pH
+420	0
+30	6.5
0	7.0
-6	7.1
-12	7.2
-18	7.3
-24	7.4
<b>-30</b>	<b>7.5</b>
-60	8.0
-90	8.5
-420	14.0

## TROUBLESHOOTING

- No lights on.**
1. Check the circuit breaker and/or receptacle for proper operation. Connect to functional grounding-type GFCI protected power source.
  2. Check for a damaged power connector.
  3. Check internal fuse (1A slow blow) marked F7 on Power Board.
- Alarm lights and buzzer on.**
1. Verify that the filtration system is functioning properly, water flow is adequate and water chemistry is in balance.
  2. Verify that sensor and power cables are properly connected to the respective connectors on the controller.
  3. Check the operation of the chemical feeders (pumps or erosion feeder).
  4. Verify that the (optional) flow sensor is properly installed.
- Illogical value displays.**
1. The sensor cable connections may be reversed. Verify that the sensor cables are properly connected to their respective BNC connectors on the controller unit.
  2. Verify that the filtration system is functioning properly, the water flow is adequate, and the water chemistry is in balance.
- No Chemical feed.**
1. Check FLO setting in Setup Menu and safety flow switch on bypass line if applicable.
- No Sanitizer feed.**
1. Make sure the AUTO feed light is on.
  2. Check the setpoint.
  3. Check relay fuse (5A slow blow) marked F1 and F2 on Power Board.
- No Acid/Base feed.**
1. Check pHF setting in Setup Menu for Acid or Base feed.
  2. Make sure the AUTO feed light for pH is on.
  3. Check the pH setpoint.
  4. Check pH relay fuse (5A slow blow) marked F3 and F4 on Power Board.
- Chlorine or bromine residual too high or too low.**
1. Remember that the pH, cyanuric acid concentration, total dissolved solids, and use of additional or alternative sanitizers will all impact the sanitizer residual level in comparison to ORP. Consider the impact of any chemicals recently added to the pool or spa.
  2. Check and adjust the setpoint.
- pH requires frequent calibration.**
1. Clean or replace the sensor as outlined in the maintenance section.
- Inconsistent or slow readings.**
1. Verify that the sensor cables are properly connected to their respective BNC connectors on the controller unit.
  2. Clean the sensors as outlined in the maintenance section.
  3. Check to verify that all the electrical equipment in the facility pump room is properly grounded.
  4. Replace the sensors if needed.
- Chemical feeder runs continuously.**
1. Make sure the AUTO feed mode is selected.
  2. Verify that the chemical feeders are properly connected to their respective connectors on the controller unit.
- pH or Sanitizer overshoots setpoint.**
1. Increase the width of the proportional zone.
  2. Check the dilution of sanitizer or acid/base solution.
- pH or Sanitizer does not reach setpoint.**
1. Decrease the width of the proportional zone.
  2. Increase the concentration of sanitizer or acid/base solution.
  3. Check chemical feeders for proper operation.

## LIST OF FIGURES

Figure 1 - Equilibrium of Free Chlorine.....	3
Figure 2 – CH250 Installation on Main Line.....	4
Figure 3 – ORP or pH Sensor .....	4
Figure 4 – CH250 Installation with Bypass Line .....	5
Figure 5 – Flow Cell Assembly .....	5
Figure 6 – CH255/265 Installation with 2 Flow Cells .....	6
Figure 7 - PPM Sensor Cell.....	6
Figure 8 - PPM Sensor Package.....	7
Figure 9 – Power Board.....	8
Figure 10 - Erosion Feeder Installation .....	9
Figure 11 - ON/OFF Control.....	10
Figure 12 - Proportional Control .....	10
Figure 13 - Portable Tester.....	12

## PARTS LIST

<b>MB250/255</b>	Mother Board for CH250 or CH255 (specify voltage)
<b>PB250/255</b>	Power Board for CH250 or CH255 (specify voltage)
<b>ORP</b>	ORP sensor with 10-ft BNC cable
<b>pH</b>	pH sensor with 10-ft BNC cable.
<b>PKT-2.0</b>	Set of two (2) PVC tees and compression fittings for 2 in. (50 mm) line
<b>PKT-1.5</b>	Set of two (2) PVC tees and compression fittings for 1 1/2 in. (37 mm) line
<b>PPM002</b>	0-2 PPM Chlorine Sensor with connector
<b>PPM010</b>	0-10 PPM Chlorine Sensor with connector
<b>PPM200</b>	0-200 PPM Chlorine Sensor with connector
<b>PPMSLT</b>	0-10 PPM Membraneless Sensor for Electrolytic Salt Generator with connector
<b>PPMCLL</b>	Flow Cell for Chlorine sensor
<b>PPMM01</b>	Membrane for PPM002/PPM010 Sensors
<b>PPMM02</b>	Membrane for PPM200

## OPTIONS

<b>BPL-0.5</b>	1/2 in. bypass line assembly with Y-filter, flowmeter, safety flow switch, two (2) shutoff valves and sampling tap.
<b>PWFS</b>	Rotary paddle-wheel safety flow switch.
<b>FCA</b>	Machined transparent polycarbonate flow cell assembly for sensors.
<b>XC25</b>	Sensor cable extension with BNC connectors, 25-ft (8 m).
<b>XC50</b>	Sensor cable extension with BNC connectors, 50-ft (16 m).
<b>DIAL</b>	Telephone dialer with voice messaging.

## SPECIFICATIONS

<b>Cabinet</b>	Polystyrene (9.5x7.25" or 23.5x18 cm)
<b>PPM Display</b>	0 to 10 ppm
<b>ORP Display</b>	0 to 999 mV
<b>pH Display</b>	0 to 14
<b>PPM Setpoint</b>	0 to 10 ppm or 0 to 200 ppm
<b>ORP Setpoint</b>	250 to 950 mV
<b>pH Setpoint</b>	4.5 to 9.5
<b>PPM Accuracy</b>	0.1 ppm
<b>ORP Accuracy</b>	+/- 5.0 MV
<b>pH Accuracy</b>	+/- 0.1 pH
<b>Feed Controls</b>	Off / Manual / Automatic / Proportional
<b>pH Feed</b>	Acid or Base Feed.
<b>Safety Systems</b>	Visual and Remote Alarms
<b>Control</b>	Comprehensive Diagnostic Self-Test
<b>PPM Output</b>	5 Amp/120 or 230 VAC
<b>ORP Output</b>	5 Amp/120 or 230 VAC
<b>pH Output</b>	5 Amp/120 or 230 VAC
<b>Remote Alarm</b>	Dry contact for audio, visual or telephone dialer
<b>Input Power</b>	0.25 A at 120 or 230 VAC (exclusive of pumps)