

Pyxis ST-730 Inline Turbidity Meter Series

ST-730 Series are designed for monitoring the middle range turbidity in various applications. It is more robust and tolerant to fouling, particular matters, and air bubbles comparing to other online turbidity meters designed for relatively clean water applications.

ST-730 series turbidity probe measures two optical densities and two scattering intensities at two wavelengths. This helps measure a large turbidity range and yet maintain a fine resolution. This design also helps the probe run self-diagnoses.

Typical Applications: Industrial water treatment process control, including raw water, cooling water, and wastewater. Surface water monitoring.

Other chemical processes with middle range of turbidity.



Features of the Pyxis ST-730

- Dual-wavelength: white LED and IR LED 90° scattering to achieve more reliable and accurate reading in a complex flow system.
- A small footprint compact design, similar to an industrial pH probe.
- Isolated 4-20mA output. No need for additional transmitter for easy connection to PLC and DCS.
- Isolated RS-485 output embedded for easy trouble shooting and calibration.

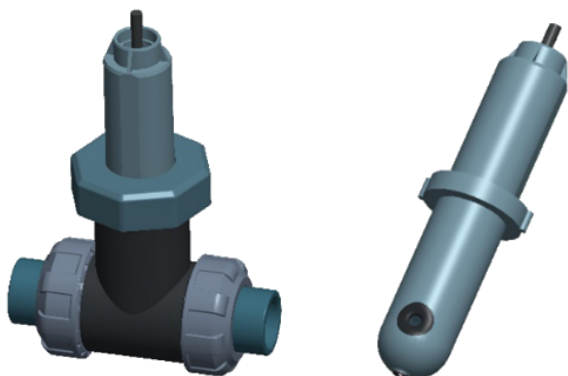

Specifications

- Range: 0 to 10 NTU model ST-731
- Range: 0 to 100 NTU model ST-730
- Range: 0 to 1,000 NTU model ST-730B
- Range: 0 to 10,000 NTU model ST-735
- Material: CPVC
- Installation: Custom tee with 3/4" NPT ports
- Pressure: Up to 100 psi
- Outputs: Isolated 4-20mA Analogue and RS-485 Digital
- Supporting ModBus protocol
- Rating: IP66
- Power Supply 24-26vDC
- Dimension : Length 172.8mm
body diameter 36.5mm
- Weight 170 g
- Cable Length: 1.5 meter, terminated with IP67 connectors