

This Guide provides a basic setup for your Chemtrol PC controller. We recommend reading the Chemtrol Reference Guide for a comprehensive review (www.sbcontrol.com/reference-guides). For further support call your local dealer or Santa Barbara Control systems at 805-683-8833 or 800-621-2279.

1. Location and Electrical

Your PC controller kit should include the following: 1) one PC controller; 2) one Flow Cell Assembly (FCA); 3) one Paddle Wheel Flow Switch (PWFS); and 4) one pH sensor (blue) and one Oxidation-Reduction Potential (ORP) sensor (red). The pH sensor monitors the water's acidity and the ORP sensor monitors the activity of the sanitizer (free chlorine, bromine or ozone). PC3000 and higher models may have additional sensors.

- Mount the controller on a wall in a secure location that is: 1) in a separate or well-ventilated room, or as far as possible from corrosive chemicals and storage tanks; 2) a safe distance from power transformers, pump motors or high-voltage power lines; 3) not exposed to direct sunlight; 4) >10' (3m) from open water; and 5) <10' (3m) from the main-recirculation or bypass line, unless extension cables will be used for sensors.
- Connect the Ground lug on the right side of the cabinet to an earth ground. Use a no. 8 AWG, solid-copper conductor between this unit and any metal enclosure, equipment, water pipe or conduit within 5' of the unit. We recommend testing for ground faults by connecting the controller's power cable to a GFCI tester.

2. FCA and Connections

- Install the Flow Cell Assembly (FCA) as a bypass line, with the influent side connected to the main-recirculation line after the main pump and filter and the effluent side connected to the suction side of the pump. Install the pH and ORP sensors by removing their rubber caps, dipping in water to loosen if needed. Insert sensors into the compression fittings in the FCA. Tighten enough to avoid leaks; over-tightening can damage the sensors. Keep the protective caps inside the sensor box or controller cabinet for later use in storage or shipping. When storing or shipping either sensor, fill the protective cap with the original storage solution or with salt water and re-fit it over the sensor tip.
- Install the Paddle Wheel Flow Switch (PWFS) on the influent side of the bypass line before the FCA. Confirm water flow through the PWFS by observing the spinning wheel. Connect the PWFS cable into the four-pin circular connector labeled "PWFS" on the cabinet side, not the main-flow connector labeled "FLOW."
- Connect the pH and ORP sensor cables to their BNC connectors labeled on the cabinet side.
- If using a PPM sensor, connect the provided Clear Acrylic Cell to the FCA via 1/4" tubing. Prepare the PPM sensor per the instructions provided in its box. Connect the PPM cable to the circular connector labeled "PPM" on the cabinet side.
- If using a Temperature sensor, install it near the pH and ORP sensors, on the bypass with a 1/2" NPT PVC fitting, or threaded directly into the main line. For a Conductivity/Temperature sensor, note the direction of the bored hole on the sensor tip and align the hole in the direction of the water flow using a 3/4" NPT PVC fitting. Connect either cable to the four-pin circular connector labeled "TDS/TEMP" on the cabinet side.
- Connect the plugs of the chemical-feed pumps to the receptacles labeled on the cabinet bottom, or wire them directly to the terminal blocks of the labeled relays.
- Connect an external Alarm to the terminal block of the labeled relay, if applicable.

3. Controller Setup

- To navigate through the menus, use the Up and Down arrows to scroll through lines, the Right Arrow to enter a sub-menu or to change a setting, and Left Arrow to return to a previous menu. Use the Left Arrow from the Main Menu to see the controller model and version.
- Confirm the functions that are installed with the controller. Navigate to the bottom line of the Main Menu where the date is displayed and Right Arrow to access the CONFIGURATION Menu.
- Navigate to CONFIGURATION/Operations to confirm that Bypass Line is set to YES, Flow Pulse set to YES, Flow Switch set to NO and Probe Monitor set to OFF.
- We strongly recommend using a bypass line with a flow switch, such as the standard Chemtrol Flow Cell Assembly (FCA) and Paddle Wheel Flow Switch (PWFS). Confirm that flow rate through the bypass line, displayed on the Pump line of the Main Menu, is between 1 gpm and 9 gpm. If not in this range, adjust the effluent ball valve on the FCA.

- If no flow switch is being used, set Bypass Line to NO. **Warning:** *In this case a lack of water flow by the sensors will cause misleading readings, resulting in potentially excessive and hazardous chemical feed.* Interlock the controller's power with the power of the main-recirculation pump, thus preventing chemical feed when the main pump is off. If flow is interrupted for another reason such as a leak, then Time Limit must be set to a low value to prevent excessive feeding (see below).
- Set each feed control. From the Main Menu, navigate to pH, ORP, etc., then:
 - > For pH, enter the pH Setpoint, then set whether control is via Acid or Base feed.
 - > For ORP control, enter the Setpoint, then set to Oxidizer if feeding Chlorine or other oxidizer.
 - > For PPM control, in SANITIZER enter the Setpoint, set to Sanitation and select NO for San/ORP Boost.
 - > For each, set the Alarm Low and Alarm High values. This range triggers an audible alarm on the controller or an external alarm. Keep defaults or change ALARM OPTIONS as desired.
 - > For each, set the Time Limit to the desired maximum time allowed, in minutes, for continuous feed. This prevents over-feeding in case of malfunction or an empty feed tank. An appropriate value is typically ~3/4 the turnover rate of the main recirculation.
 - > For each, in the first line change control model from OFF to AUTOMATIC. In most cases set to ON/OFF control (see below for PROPORTIONAL or 4-20mA). Next set the Dead Band to the desired percentage, above or below the Setpoint, wherein feed is activated. A minimum of 1% is necessary to prevent over-working the relay. Defaults are 1% for all controls, except for 10% for PPM.
 - > If both ORP and PPM are in use, define control by setting one to AUTOMATIC and the other to OFF.
- A water body that is small or has a long-return circulation may warrant Proportional or 4-20mA control mode. These slow the feed rate as readings approach the Setpoint, via feeding intermittently or slowing the pump. To change a feed's Control Mode:
 - > Re-set Control Mode to AUTOMATIC and then to PROPORTIONAL for standard pumps or 4-20mA for 4-20mA pumps.
 - > Set the Progressive Zone, wherein the feed rate will be slowed. An appropriate value is typically +/- 10% of the Setpoint value.

4. Sensor Calibration

- Sensors must be in recirculating water for the calibration process.
- Conduct a complete water test with a manual test kit.
- Calibrate the pH sensor before any other sensors:
 - > Confirm that Acid or Base is correctly selected in the pH Menu, found after setting the pH Setpoint.
 - > Re-calibrate pH if needed. Navigate to pH/CALIBRATE, select TEMP compensation NO by pressing the Right Arrow. Select 1 Point (offset). Enter the test kit's pH value and press OK.
- ORP is a direct reading that does not require calibration.
- Calibrate the Temperature or Conductivity/Temperature sensor, if installed, similarly to the steps for pH, with a one-point calibration being sufficient.
- Initialize, acclimate and calibrate the PPM sensor, if applicable:
 - > Turn off the controller and connect the PPM sensor cable. Turn on the controller and wait 2 hours for the sensor to acclimate prior to conducting an initial calibration. Acclimate another 24 hours prior to conducting a final calibration.
 - > For both calibrations, if the controller PPM value differs significantly from the test kit, navigate to SAN/Calibrate/2-Point Calibration. This calibration adjusts both the intercept and slope of a straight line. The low-value calibration point is by default 4mA = 0 PPM. Enter the High Point using the test kit's PPM value.

5. Network Setup

For the Network Option for your controller, see the Web Server Account Form at www.sbcontrol.com/web-access-options, follow the connection steps, fill out the form and submit to server@sbcontrol.com.

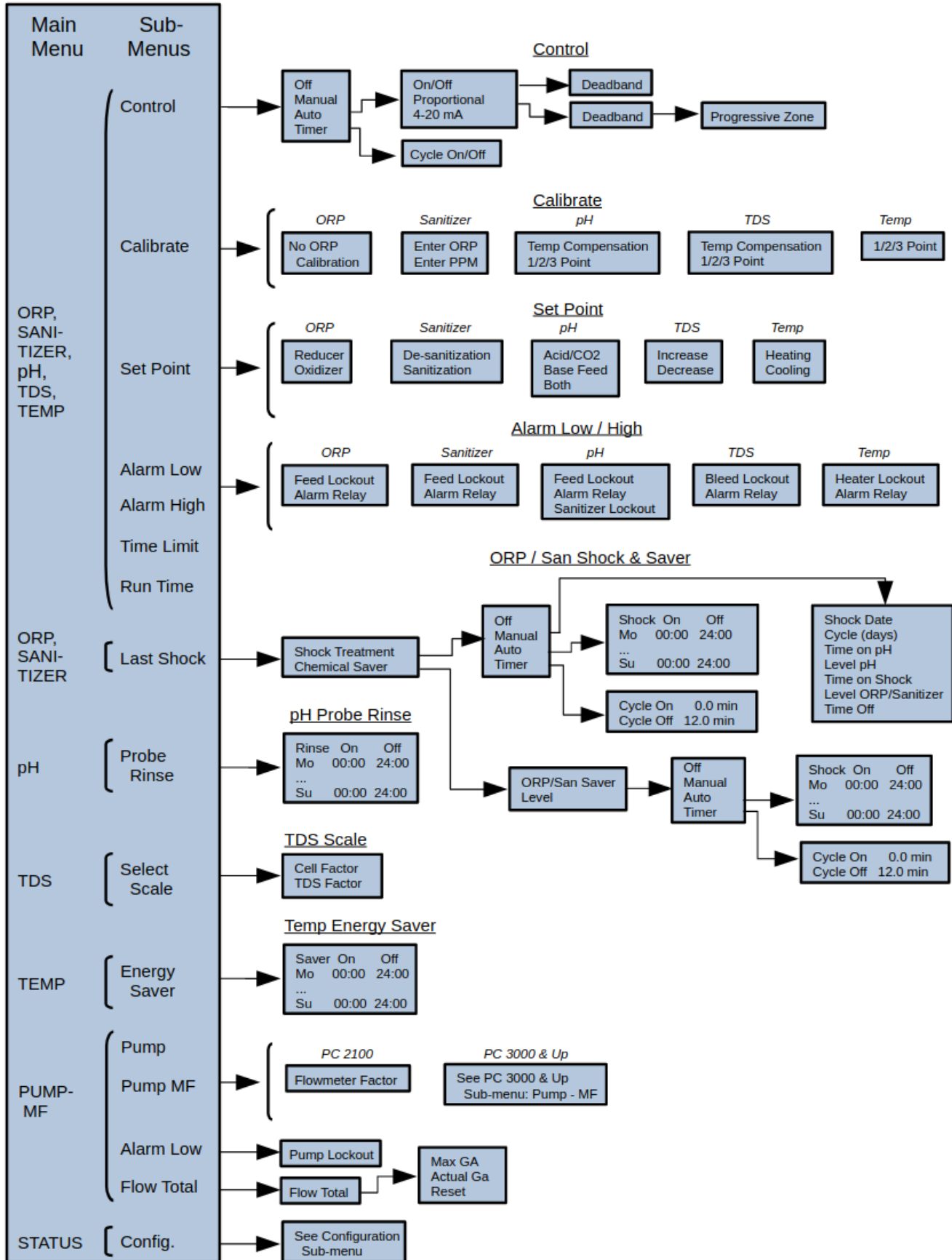

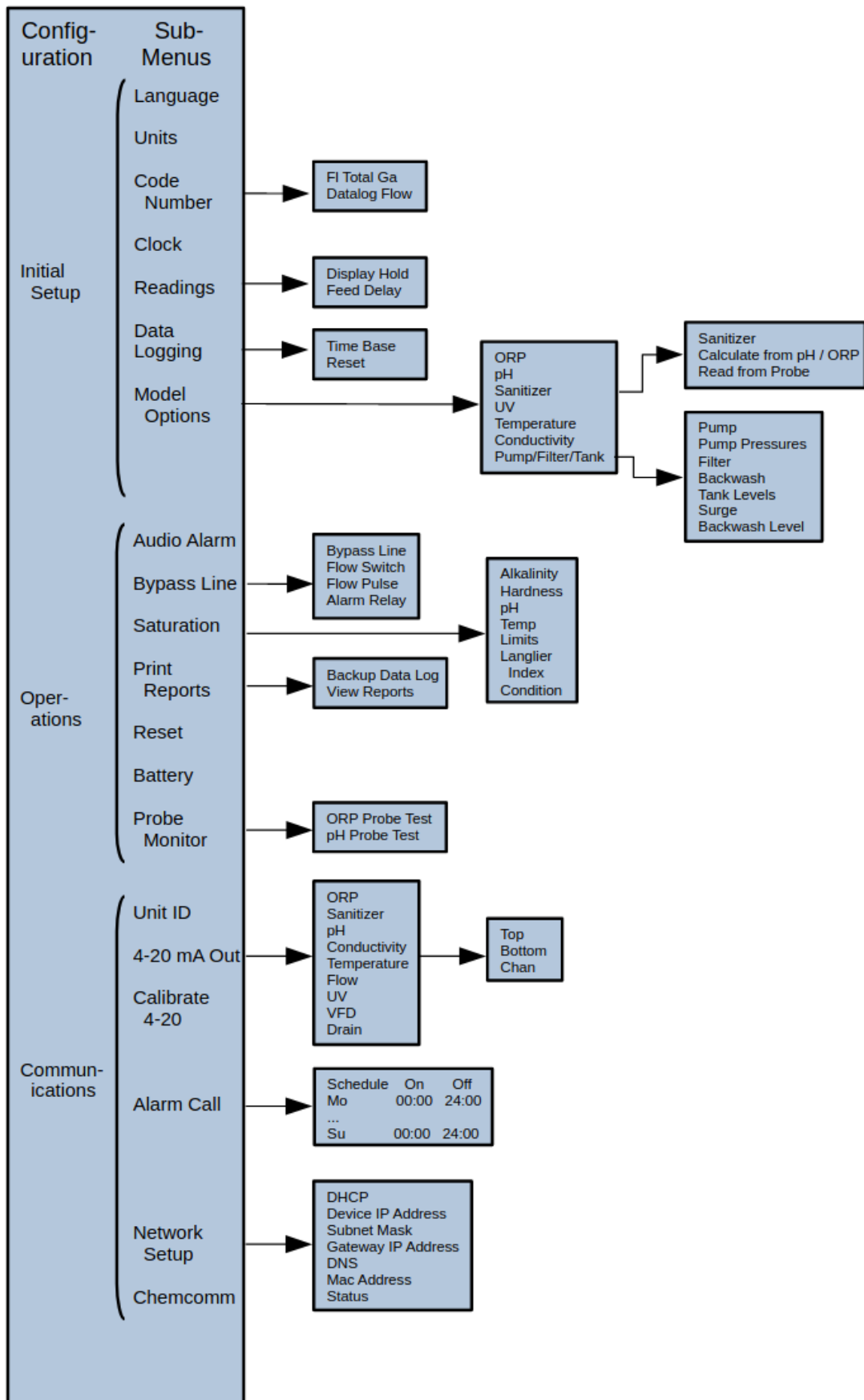

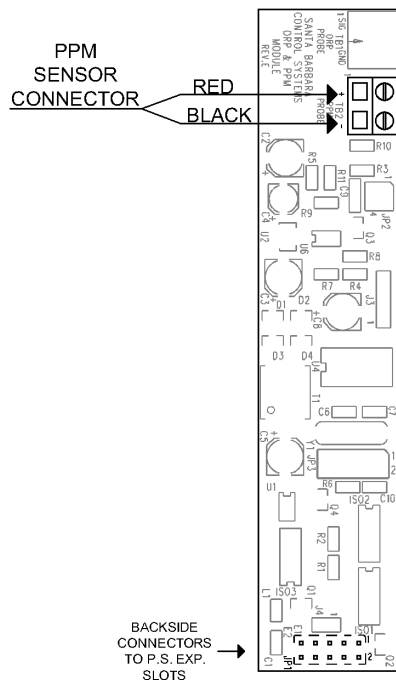
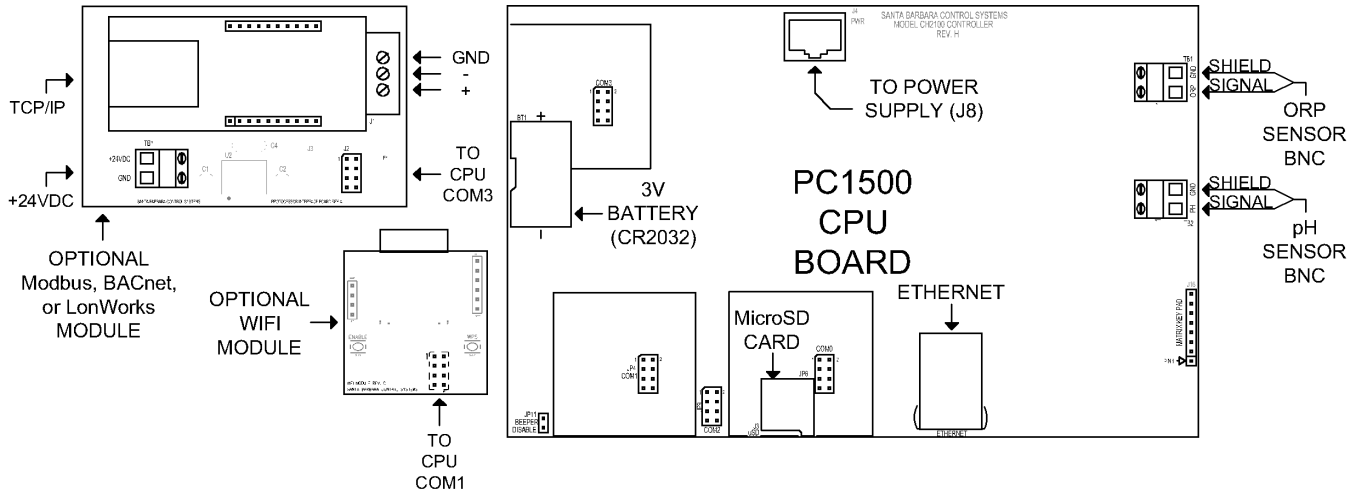

**PC1555
PPM
SENSOR
MODULE**

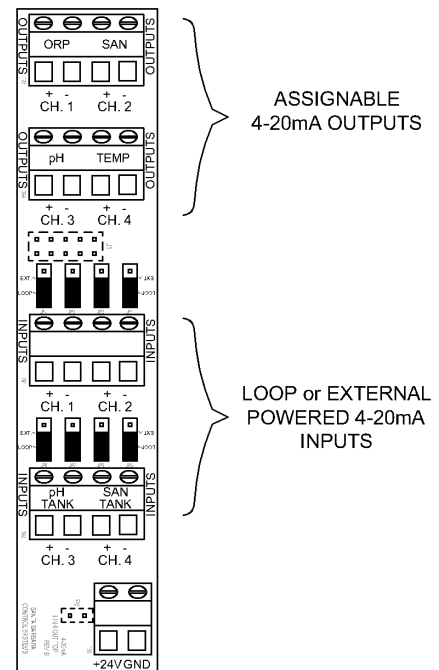

**OPTIONAL
4 IN 4 OUT
4-20mA
MODULE**

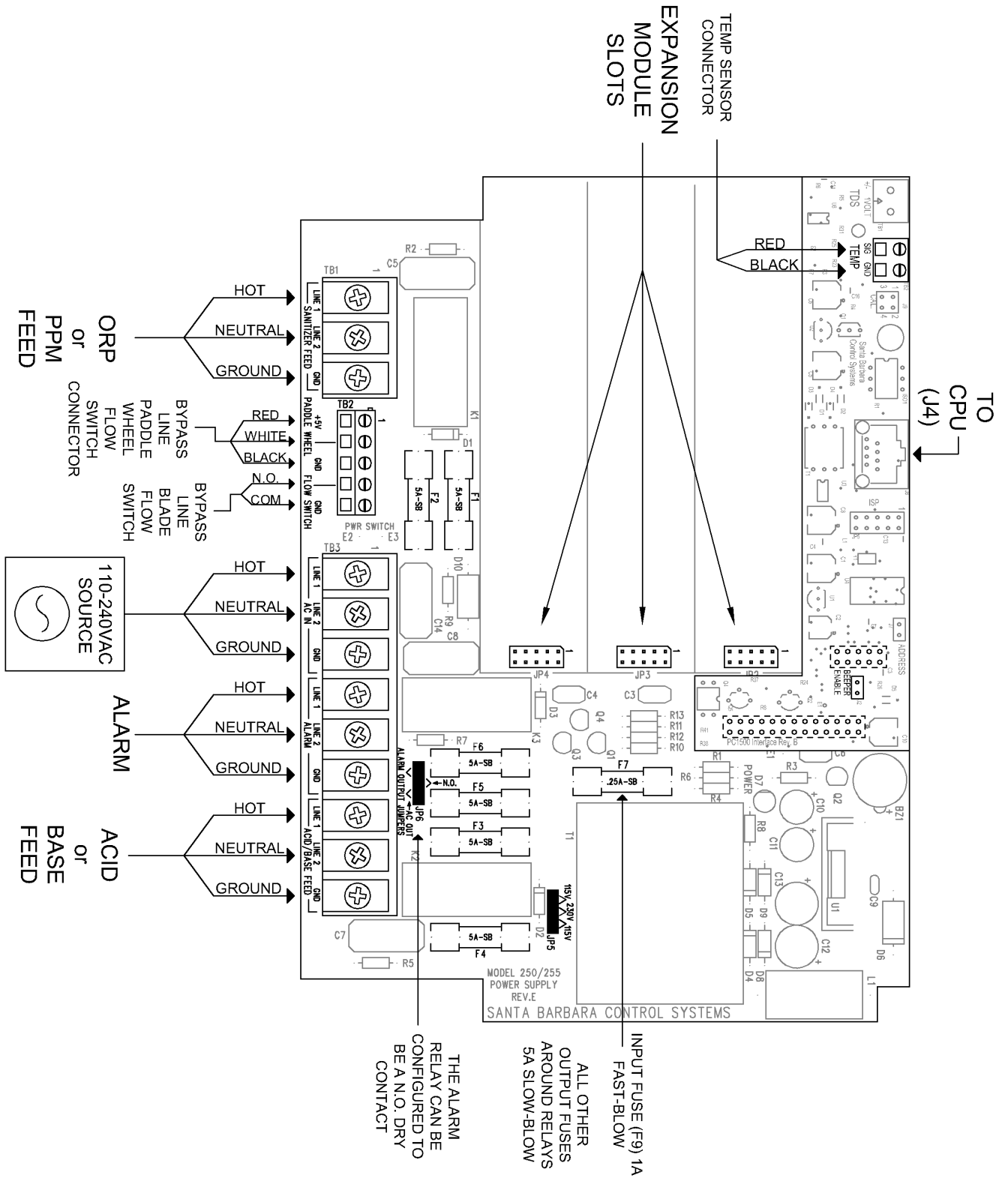

IMPORTANT SAFETY INSTRUCTIONS

1. READ AND FOLLOW INSTRUCTIONS

2. WARNING - Not for use by unsupervised children.

3. A grounding connector is provided to connect to earth ground a minimum 8 AWG solid-copper conductor between this unit and any metal equipment, metal enclosures or electrical equipment, metal water pipe or conduit within 5 feet of this unit.

4. DANGER - Risk of injury: a) replace a damaged cord immediately, b) do not bury cord, c) connect to a grounded, grounding-type receptacle only.

5. WARNING - We recommend using this product with a power source that has a ground-fault circuit interrupter (GFCI). With the controller disconnected from the power source, press the GFCI's Test button. Connect the controller to confirm that it does not power on. Disconnect the controller again and then press the GFCI's Reset button. Re-connect the controller to confirm that it does power on. If the unit behaves differently, there is a flowing ground current posing a risk of possible electrical shock. Disconnect the power until the fault has been identified and corrected.

6. DANGER - Risk of electrical shock. Install > 5' (1.5m) from inside wall of tub, spa or pool using nonmetallic plumbing.

7. DANGER - Risk of electrical shock. Do not allow any electrical appliance within 5' of tub, spa or pool.

8. WARNING - To reduce risk of injury:

a) Spa water should be <104 deg. F (<40 deg. C). Lower temperatures are recommended for young children or when spa use exceeds 10 mins.

b) Possibly pregnant women should limit spa temperatures to <100 deg. F (<38 deg. C).

c) User should measure water temperature with an accurate thermometer before entering a tub or spa.

d) Alcohol, drugs or medication use before or during spa or hot tub use may lead to unconsciousness and possible drowning.

e) Persons obese or with a medical history of heart disease, low or high blood pressure, circulatory-system problems or diabetes should consult a physician before using a spa.

f) Persons using medication should consult a physician before using a spa.

9. SAVE THESE INSTRUCTIONS.

If your Chemtrol controller includes temperature, read these additional safety instructions.

1. To adjust temperature, scroll to TEMP in the Main Menu, press the Right Arrow, scroll to Setpoint and set desired temperature.
2. Check the water temperature with an accurate thermometer.
3. Prolonged immersion in hot water may induce hyperthermia. Hyperthermia occurs when the internal temperature of the body reaches a level several degrees above the normal body temperature of 98.6°F. The symptoms of hyperthermia include an increase in the internal temperature of the body, dizziness, lethargy, drowsiness and fainting. the effects of hyperthermia include (1) failure to perceive heat, (2) failure to recognize the need to exit spa or hot tub, (3) unawareness of impending hazard, (4) fetal damage in pregnant women, (5) physical inability to exit spa or hot tub and (6) unconsciousness resulting in danger of drowning. **WARNING** - The use of alcohol, drugs or medication can greatly increase the risk of fatal hyperthermia.
4. This unit is “Convertible.”

If you have purchased the Chemtrol Webserver option for your PC controller, follow the steps to activate your server access.

- Connect your controller to your Local Area Network (LAN) via the ethernet cable connector on the Mother Board.
- To use DHCP, navigate to CONFIGURATION/COMMUNICATIONS/NETWORK SETUP, and set DHCP to YES. Cycle the controller's power. Next navigate to again to NETWORK SETUP and select Device IP Address to see the IP Address assigned by your LAN.
- To manually assign addresses, set DHCP to NO and enter the 12-digit IP Address. Then enter the 12-digit Subnet Mask Address, and then enter the 12-digit Gateway IP and DNS Addresses.
- Ensure that the LAN's firewall has no restrictions on port #10004 and has been configured for TCP inbound and outbound connections. To confirm connection through the LAN to the Web Server, navigate to Configuration/Communications/Network Setup. The Status on bottom line should show CONNECTED. Failure to connect indicates an issue with the LAN's physical layer, router permission, or firewall settings.
- If you have firewall restrictions, allow the controller open access to the internet through TCP port #10004, to static IP address 13.57.147.187, and to sa2.us (note: in Australia use au.sa2.us).
- The Mac address is fixed and can be found by navigating to Configuration/Communications/Network Setup/MAC Address from the Main Menu. Note this for use when filling the form on page 2.
- Fill out the Web Server Account Form on page 2 of this document, obtained from www.sbcontrol.com/web-access-options. Complete one form for each PC controller, scan and submit to Santa Barbara Control Systems via email to server@sbcontrol.com.

You may also find this form at the above web address above and fill out digitally and return to the above email address. If you have trouble connecting to the server after completing these steps, write the above email address.

If you have not purchased the Chemtrol Webserver option and wish to explore the Webserver interface, go to www.sbcontrol.com, click the "Web-server login" link at the top of the page, and login as User: guest, Password: guest. Select a controller and explore.

Please provide the following info (highlighted fields required)	
1. Installation:	
Customer Name	
Facility Name (Full)	
Facility Address	
Facility Time Zone	
Pool Name	
Controller Model	
Controller Firmware	
Controller Serial Number	
Controller MAC Address	
2a. Controller Wired Static IP Addresses (blank if DHCP):	
Device IP	
Gateway IP	
Subnet Mask	
Preferred DNS	
2b. Controller Wireless Addresses (not recommended):	
Wireless SSID	
Password	
Security Type	
Encryption Algorithm	
3. Administrator:	
Server Account Admin. Full Name	
Title	
Telephone #	
Email	
Server Admin Username	
Server Admin PW (Case sensitive)	
4. Alert Recipients:	
Email Addresses of Recipients	
1:	
2:	
3:	
Phone #s of Recipients (xxx-xxx-xxxx format, in same order as emails)	
1:	
2:	
3:	